

TM 138-25

Product information

Drummotors

TM 138-25



Van der Graaf
Power Transmission Equipment

www.vandergraafpte.nl





The TM 138's
playground



TM 138-25

A wide range of applications

Van der Graaf has achieved a prominent position on both the domestic and international market with its "GV" Drummotors.

The "GV" Drummotor has found success in a wide range of applications including the following: automotive, X-ray, construction, postal, courier, mining, aggregate, airline baggage, package flow, tyre manufacturing, fish processing, poultry processing, meat processing, agriculture, fruit and vegetable, farming, forestry, baking, dairy and many more.

- 4 Introduction
- 5 Selection table
- 6 Selection table Dahlander motors
- 7 Dimensions Drummotors mild steel
- 8 Dimensions Drummotors stainless steel
- 9 Dimensions Taildrums mild steel
- 10 Dimensions Taildrums stainless steel
- 11 Dimensions bracket
- 12 Cable exit
- 13 Cross sectional / parts description
- 16 Options
- 19 Product range
- 20 Contact us



Selection table

TYPE TM 138.25	Power kW	Beltspeed m/s at 50 Hz						Min. L mm Design A	Min. L mm Design B	Full load curr. 400 V - 50 Hz I = ... A	Weight kg L=350	
		Beltpull N										
415 Z	1,10	1,40 745	1,10 950	0,90 1160	0,55 1925			350	350	2,8	23	
210 Z	0,75	2,80 255	2,20 325	1,80 395				300	325	1,4	22	
410 Z	0,75	1,40 510	1,10 650	0,90 790	0,70 1015	0,55 1295		300	325	1,9	22	
410 PL2		0,32 2155	0,26 2655	0,22 3135	0,17 3800			350	375			
275 Z	0,55	2,80 185	2,20 240	1,80 290				275	300	1,1	20	
475 Z	0,55	1,40 375	1,10 475	0,90 580	0,70 745	0,55 950	0,45 1160	275	300	1,3	20	
475 PL2		0,32 1580	0,26 1945	0,22 2300	0,17 2975			325	350			
405 Z	0,37	1,40 250	1,10 320	0,90 390	0,70 500	0,55 640	0,45 780	0,35 1005	275	300	1,0	19
405 PL2		0,22 1545	0,17 2000						325	350		
405 PL3		0,050 3800	0,039 3800	0,033 3800	0,026 3800				375	400		
605 Z	0,37	0,27 1300						275	300	1,1	20	
605 PL2		0,15 2270	0,12 2835					325	350			
434 Z	0,25	1,40 170	1,10 215	0,90 265	0,70 340	0,55 430	0,45 530	0,35 680	250	275	0,7	18
834 Z	0,25	0,27 880	0,22 1080	0,17 1395				275	300	1,0	20	
834 PL2		0,13 1770	0,11 2090	0,09 2555				325	350			
834 PL3		0,025 3800	0,019 3800	0,016 3800	0,013 3800			375	400			
825 Z	0,18	0,27 635	0,22 775	0,17 1005				275	300	0,8	19	
818 Z	0,13	0,27 455	0,22 560	0,17 725				250	275	0,6	18	
1218 Z	0,13	0,13 950	0,11 1125					300	325	0,9	22	
1218 PL2		0,09 1330	0,08 1495	0,06 1995				350	375			
1218 PL3		0,016 3800	0,013 3800	0,011 3800	0,009 3800			400	450			
1213 Z	0,10	0,13 730	0,11 865					275	300	0,6	20	

Available standard facewidth's: 250 - 275 - 300 - 325 - 350 - 375 - 400 - 450 - 500 - 550 - 600 - 650 - 700 - 750 - 800 - 850 - 900 - 950 - 1000 mm

When an electro-mechanical brake is fitted, the minimum facewidth is increased by 75 mm

The total weight of a Drummotor grows approx. 2,0 kg per 100 mm

Maximum beltpull: 3800 N (Imax on request or on data plate)

Available torque: (Beltpull N x drum diameter m) / 2 Nm

Selection table Dahlander motors

TYPE TM 127.25	Power kW	Beltspeed m/s at 50 Hz						Min. L mm Design A	Min. L mm Design B	Full load curr. 400 V - 50 Hz I = ... A	Weight kg L=350	
		Beltpull N										
475/210 Z	0,55/0,75	1,40/2,80 375/255	1,10/2,20 475/325	0,90/1,80 580/395	0,70/1,40 745/510	0,55/1,10 950/650	0,45/0,90 1160/790	300	325	1,4/1,7	22	
437/275 Z	0,27/0,55	1,40/2,80 185	1,10/2,20 240	0,90/1,80 290	0,70/1,40 375	0,55/1,10 475	0,45/0,90 580	0,35/0,70 745	275	300	0,9/1,3	20
825/405 Z	0,18/0,37	0,35/0,70 500	0,27/0,54 650	0,22/0,44 800	0,17/0,34 1035				275	300		
825/405 PL2		0,13/0,26 1310	0,11/0,22 1545	0,09/0,18 1890					325	350	1,0/0,9	20
825/405 PL3		0,025/0,050 3800	0,020/0,040 3800	0,017/0,034 3800	0,013/0,026 3800				375	400		

Available standard facewidth's: 275 - 300 - 325 - 350 - 375 - 400 - 450 - 500 - 550 - 600 - 650 - 700 - 750 - 800 - 850 - 900 - 950 - 1000 mm

When an electro-mechanical brake is fitted, the minimum facewidth is increased by 75 mm

The total weight of a Drummotor grows approx. 1,5 kg per 100 mm

Maximum beltpull: 3800 N (Imax on request or on data plate)

Available torque: (Beltpull N x drum diameter m) / 2 Nm



Dimensions Taildrums mild steel

KT 138A25

KT 138A25, mild steel Taildrum

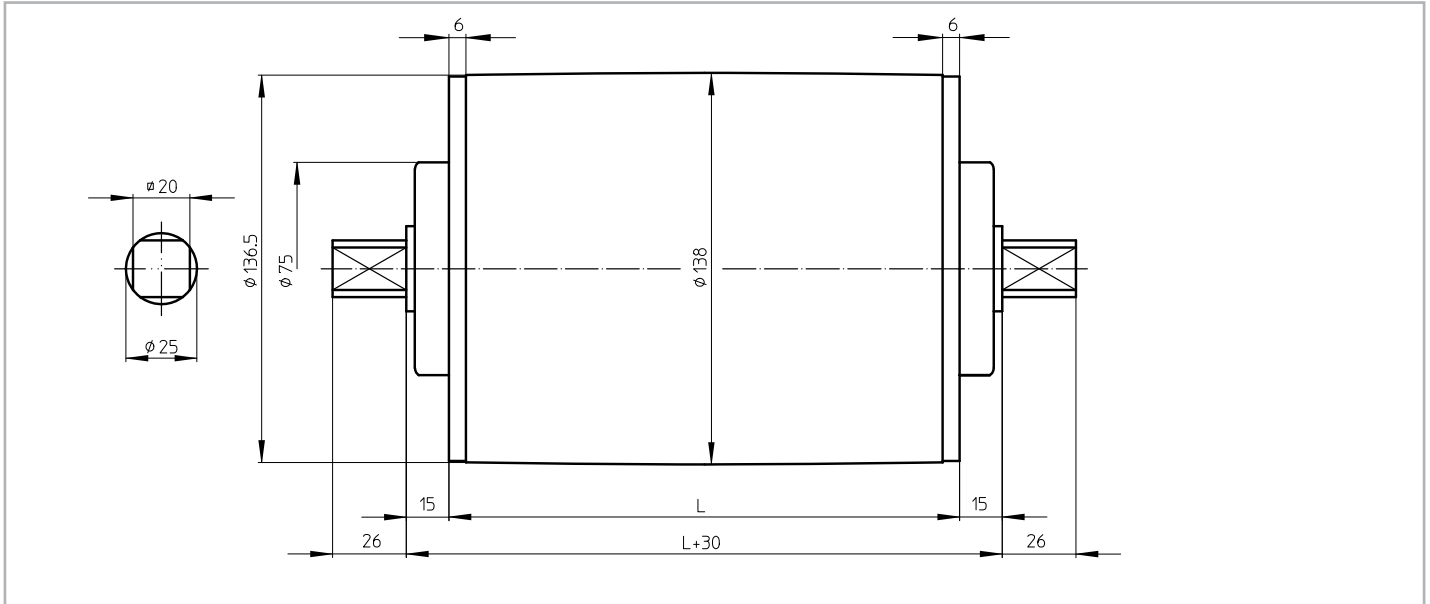

KT 138B25

KT 138B25, mild steel Taildrum

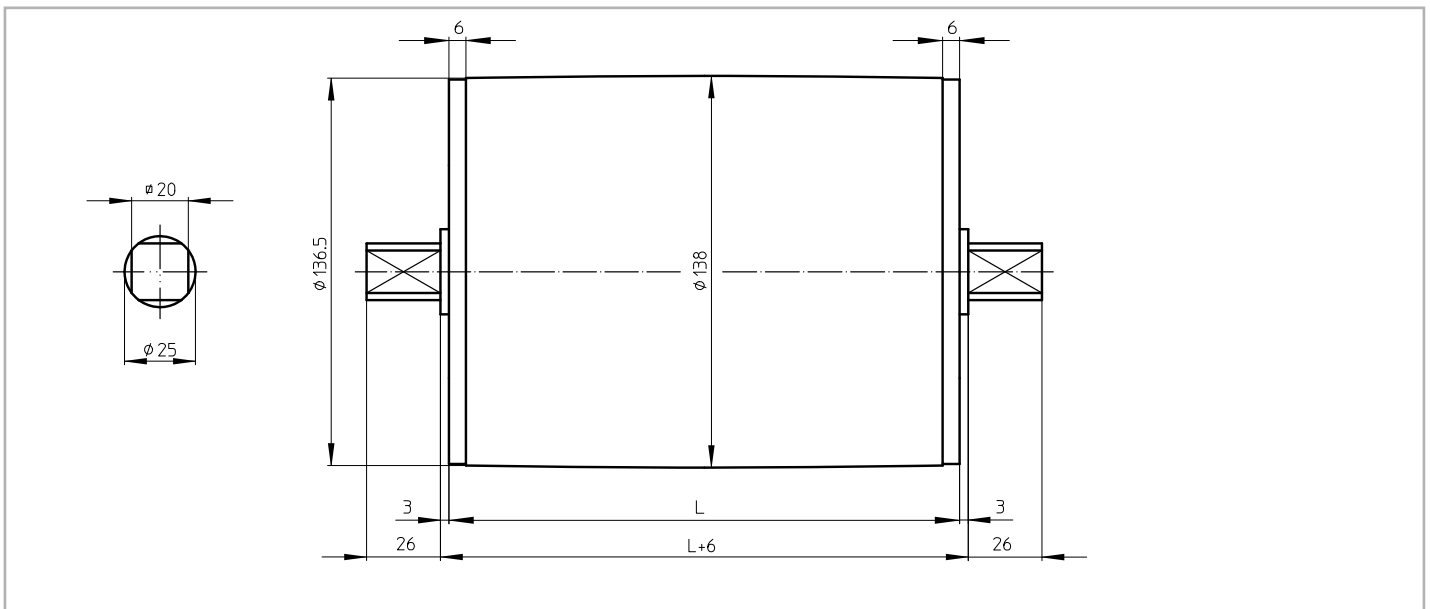

Dimensions Taildrums stainless steel

KT 138A25 CR

KT 138A25 CR, stainless steel Taildrum with CR sealing

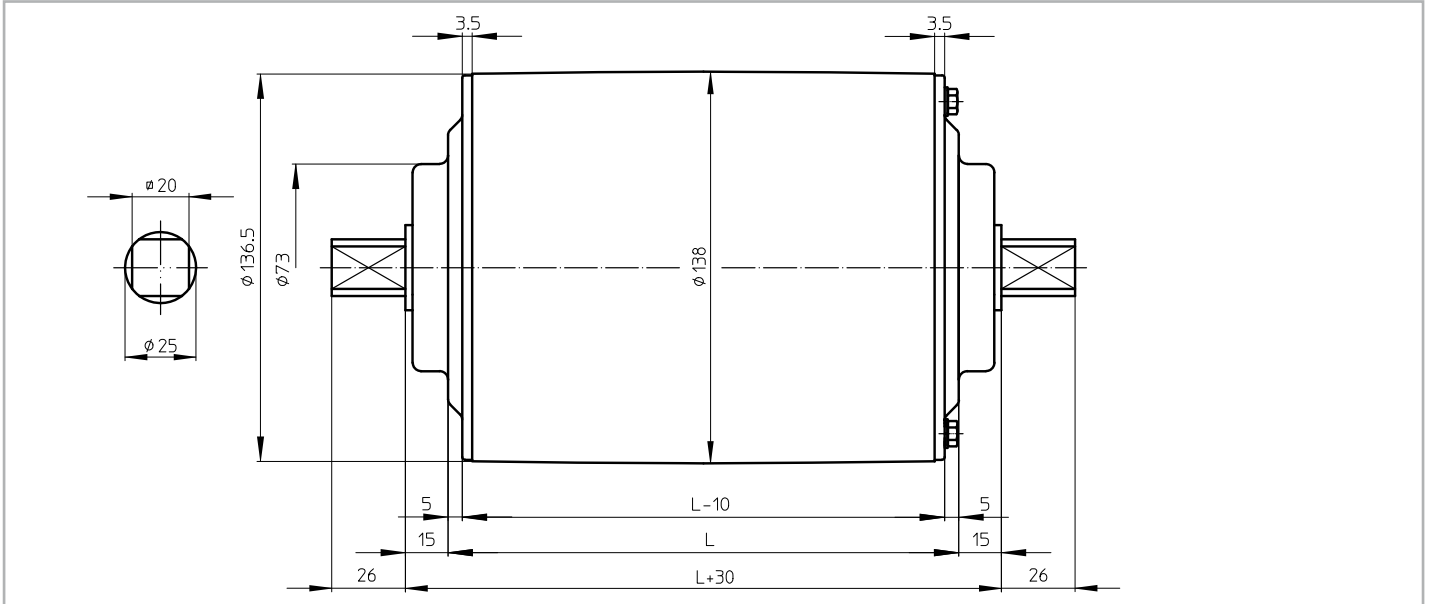

KT 138B25 CR

KT 138B25 CR, stainless steel Taildrum with CR sealing

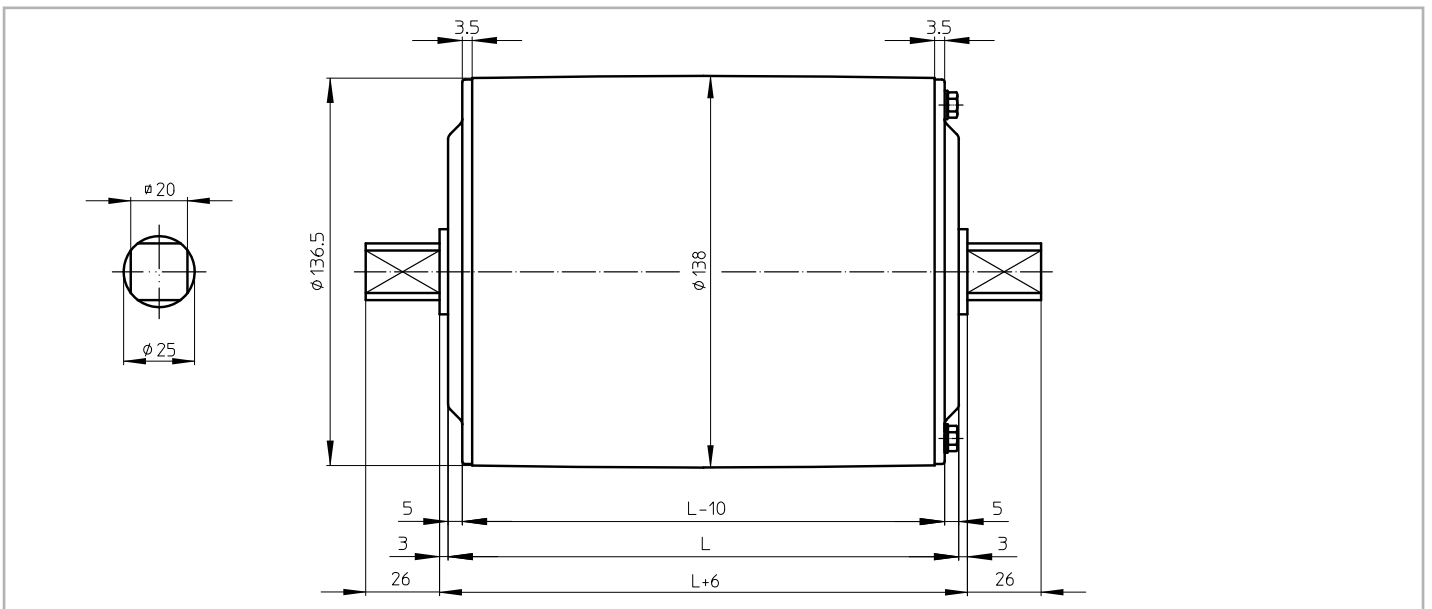



Dimensions bracket

AB 25

AB 25, cast iron or stainless steel bracket

Weight: 1,2 kg per pair

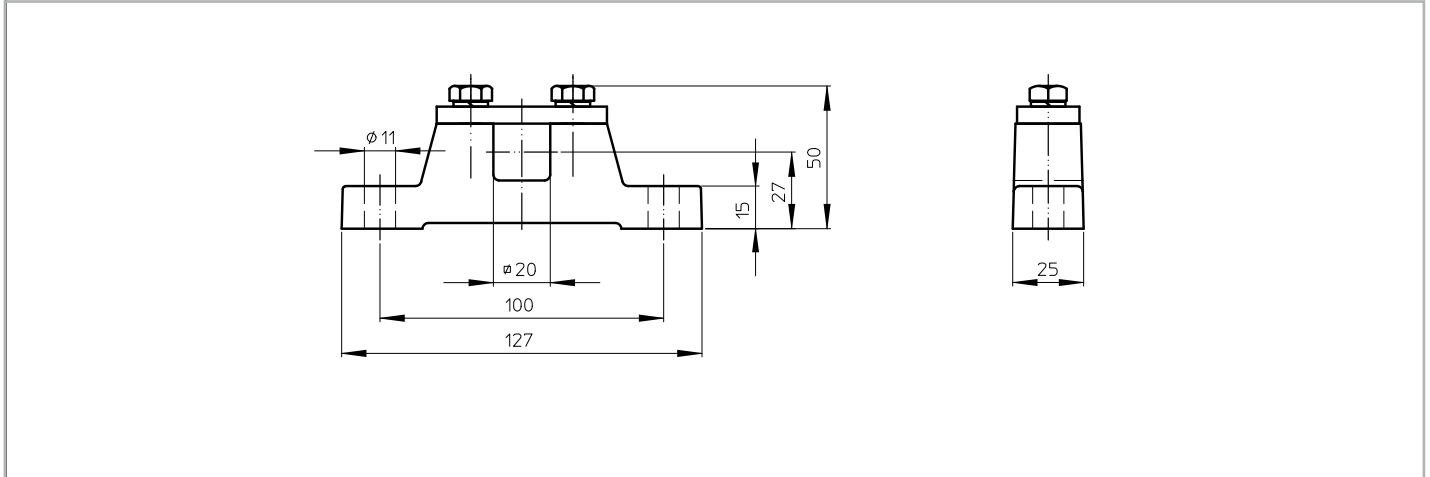

Cable exit

Standard design of a TM 138-25 is with a cast iron junctionbox. For stainless steel design, this can be either a polyamide or stainless steel junctionbox.

On request a Drummotor can be fitted with a cable. In this case it is important to know the available voltage (preferably 1 voltage), the length of the cable, whether the cable is shielded or not and the type of cable exit.

An overview of available cable exits is shown below.

Option 1

Straight cable exit with cable gland

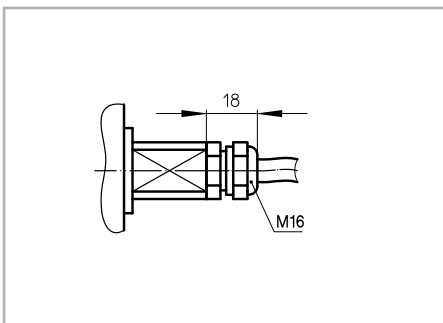

Option 3

Elbow cable exit with cable gland
(minimum facewidth increases with 25 mm)

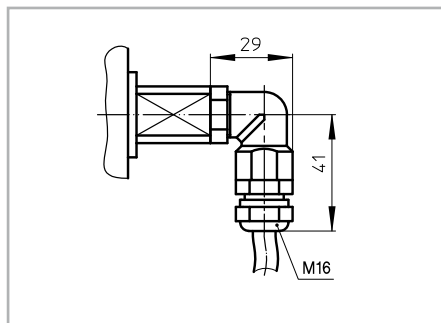

Option 4

Open cable exit (minimum facewidth increases with 25 mm)

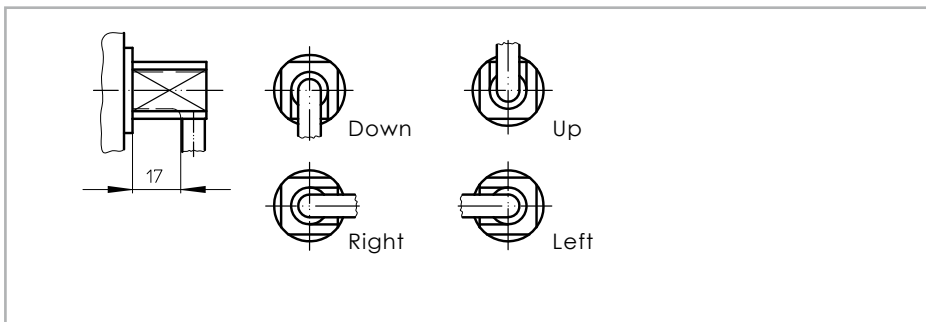



TM 138A25 Z

Legenda

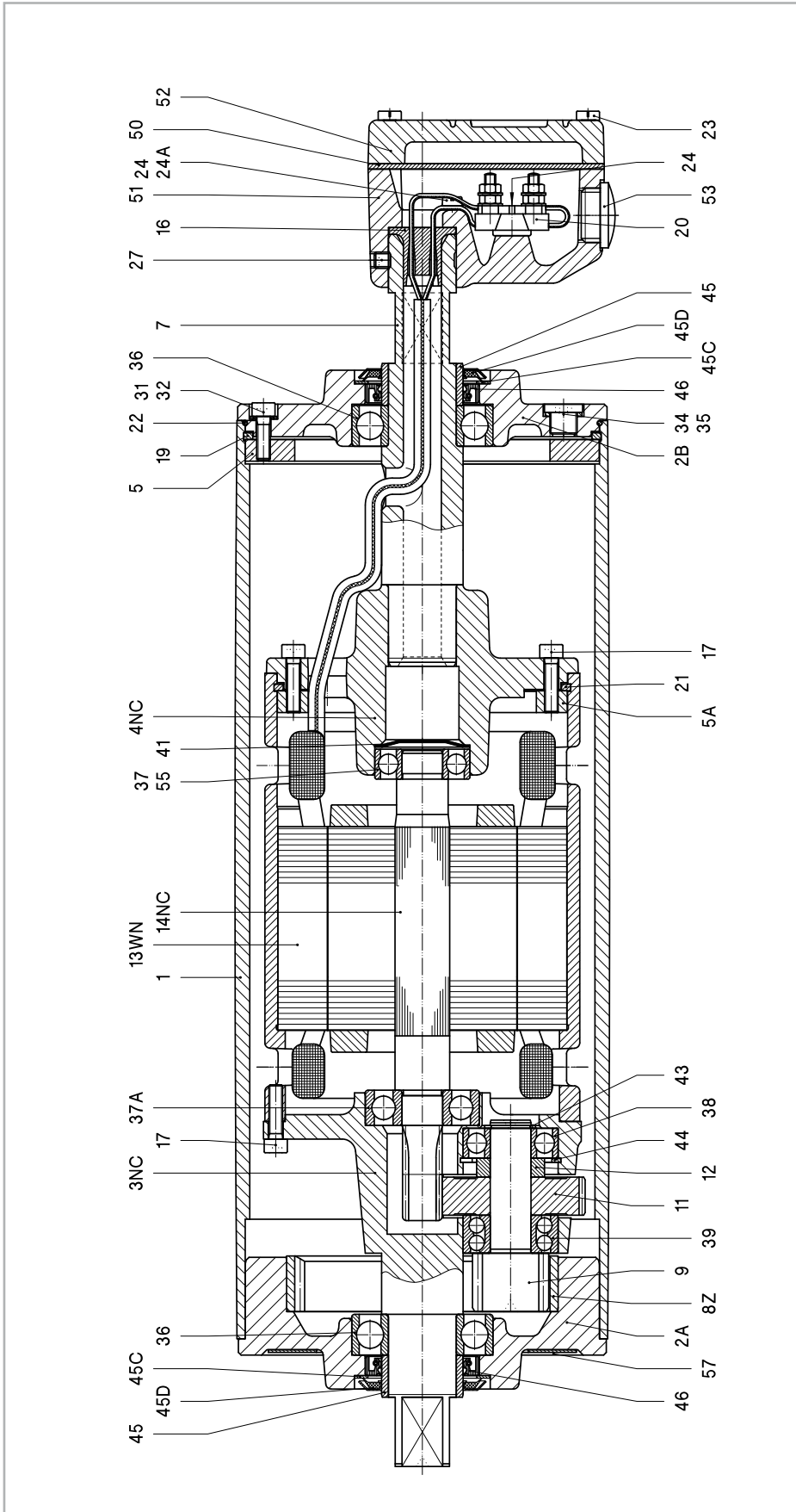

Remark: Drummotor also available in B-design (TM138B25 Z)

1	Shell	11	Gear	23	37A	Ballbearing	50	Seal
2A	Endflange	12	Distance ring	24	38	Ballbearing	51	Junctionbox
2B	Endflange	13WN	Stator	24A	39	Double-row ballbearing	52	Junctionbox cover
3NC	Gearhousing	14NC	Rotor	27	41	Locking disc	53	Stopping plug
4NC	Motorflange	16	Cable passage	31	43	Circlip	55	Ballbearing incl. backstop
5	Mountingring	17	Int. hex screw	32	44	Circlip	57	Dataplate
5A	Mountingring	19	Springring	34	45	Bearing race		
7	Hollow shaft	20	Terminalboard	35	45C	Shim plated		
8Z	Internal gear	21	Springring	36	45D	Gammaring		
9	Pinion	22	O-ring	37	46	Oilseal		



KT 138A25

Legenda

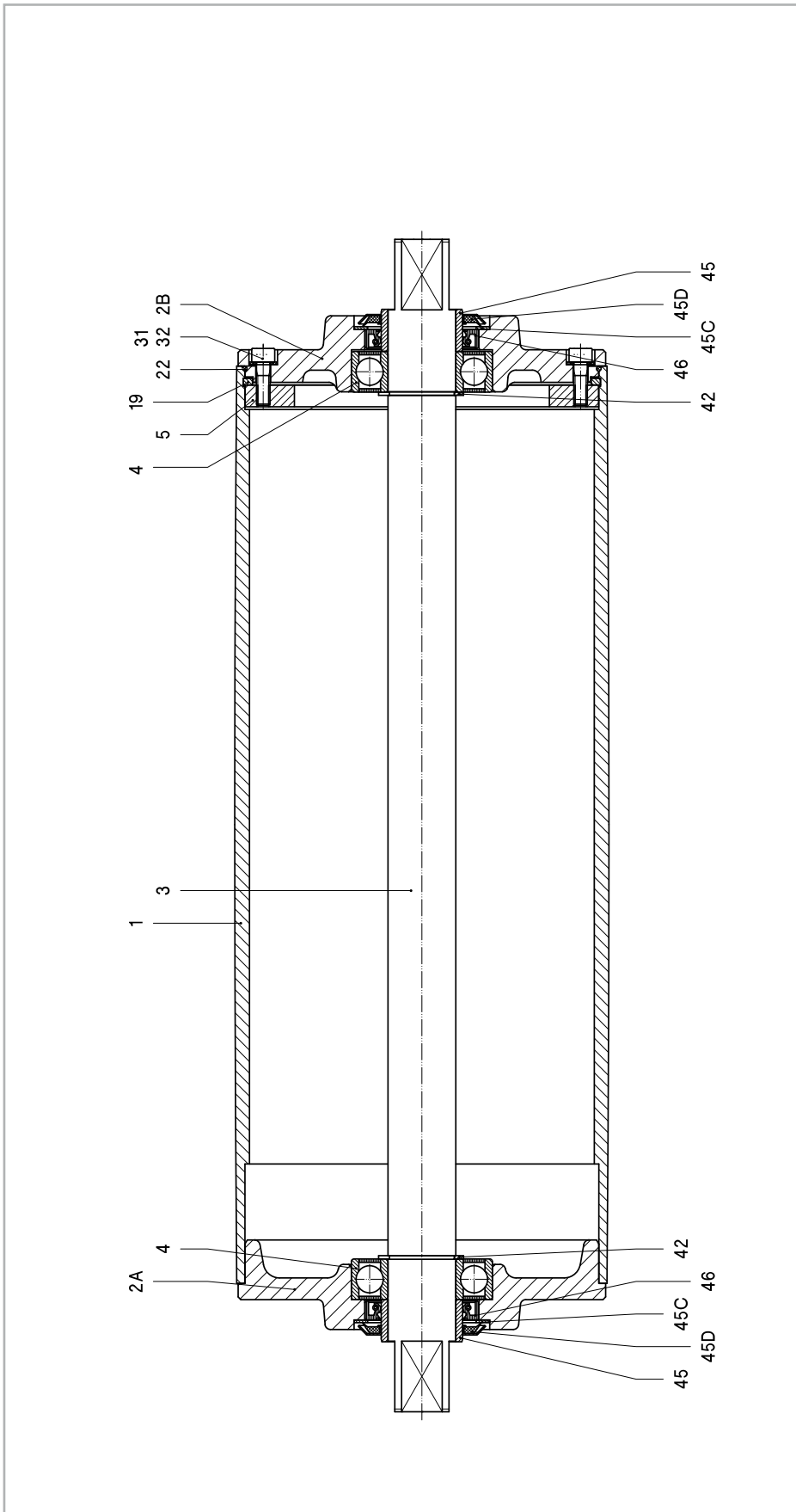

Remark: Taildrum also available in B-design (KT138B25)

1	Shell	42	Circlip
2A	Endflange	45	Bearing race
2B	Endflange	45C	Shim plated
3	Shaft	45D	Gammaring
4	Ballbearing	46	O-liseal
5	Mountingring		
19	Springring		
22	O-ring		
31	Int. hex screw		
32	Washer		

Material

The external parts of the Drummotor are made from mild steel and cast iron. Depending on the application it is also possible to manufacture in stainless steel (complete or part). You can choose between stainless steel 304 (general food industry) and stainless steel 316 (salt water applications).

Backstop - Brake

If an inclined belt conveyor is stopped fully loaded, it could run backwards.

To prevent this we can install a backstop. One of the bearings in the Drummotor is replaced by a one way bearing. The way this bearing is installed determines the direction of rotation of the drum. TBRH indicates a cw rotation and TBLH ccw.

In situations where a Drummotor needs to be able to drive in both directions it is not possible to use a backstop. In this case we use a brake. When an declined belt or a horizontal belt needs to be stopped quickly to pick or place items a brake is the best solution.

Inclined position

Sometimes a Drummotor needs to be installed on an inclined or even vertical position. This is possible, but we need to make adjustments to the oil level in the drum as the oil will flow to the lower side of the Drummotor causing the top bearing to run without lubrication. To prevent problems we will need to know the installation angle so we can fill the drum with extra oil and fit a double sealed bearing on the upper side.

Thermal protection

A Van der Graaf Drummotor can be fitted with thermal protection. This consists of either a thermistor (PTC) or bi-metal (klixon). We install these on each phase of the electric motor.

Encoder - Sensor bearing

In certain applications it is required to measure the speed or position of a conveyor belt. For this type of application we can install an encoder or sensor bearing to accurately measure rotational speed of the Drummotor.

The accuracy needed will determine the type of encoder or sensor used.

Lagging

The power produced by the Drummotor has to be transferred to the belt and lagging is used to give more friction between the Drummotor and the conveyor belt. Van der Graaf can fit your Drummotor with different kinds of lagging.

There is a difference between cold and hot vulcanised lagging. Cold vulcanised means the lagging is glued to the Drummotor usually in sheet form and the join 'welded' together. Hot vulcanising is a process where the shell is wrapped around with thin layers of rubber. The shell with the rubber is then baked in an autoclave fusing the layers together creating a seamless finish.

It is possible to cut grooves (e.g chevron or diamond) in the lagging.

Sprockets

Do you wish to use a Drummotor to drive modular belts? Van der Graaf can help you! Fitting sprockets suitable for various types of modular belts is a simple solution. The Drummotor is manufactured with a cylindrical shell and machined with a patented 'keying' system. The sprockets are simply 'slid' on and locked securely into position.

Sealings for mild steel Drummotors

RB sealing - IP 66



This is Van der Graaf's standard sealing. This type of sealing will work in most conditions.

RBS sealing - IP 66



This sealing is specifically designed for those applications where high water pressure is used for cleaning.

HD sealing - IP 66



This sealing is designed for abrasive applications, like sand, gravel and soil.

Sealings for stainless steel Drummotors

CR sealing - IP 66



This is our standard sealing for stainless steel Drummotors, a very effective, multi labyrinth sealing.

UW sealing - IP 68



This sealing is suitable for under water applications. The maximum depth is approx 2,5 m.

Options

Specification	Standard	Optional
Construction		
Shafts and bolts	Mild steel	Stainless steel
Endflanges	Cast iron	Stainless steel
Shell	Mild steel	Stainless steel
Junctionbox	Cast iron	Stainless steel or polyamide
Cable		Shielded or non-shielded
Sealing mild steel	RB	RBS, HD
Sealing stainless steel	CR	UW
Shell		
Crowned	•	
Cylindrical		•
Balanced		•
Lagging, cold vulcanised		•
Lagging, hot vulcanised		•
Lagging, FDA approved		•
Fitted with grooves, patterns		•
Sprockets		•
Electro motor		
Three-phase asynchronous	•	
Power supply	230/400 V - 50 Hz	Other voltages and frequencies on request
Two speed (Dahlander)		•
Insulation class	F	H
Thermal protection		Bi-metal or thermistor
Run by frequency inverter	•	
Other options		
Food grade oil		•
Backstop, mechanical		•
Brake, electro mechanical		•
Clutch brake, electro mechanical		•
Inclined or vertical position		•
Other facewidth's		•
Different shaft designs		•
Encoder or sensor bearing in drum motor		•
Encoder or sensor bearing in tail drum		•
Certificates		
CE	•	
UL		•
CSA		•
ATEX zone 22, dust		•
UW Under water application (IP68)		•



Product range

Our products, an overview

Drum motor type	TM 100B25	TM 113B25	TM 127.25	TM 138.25	TM 160.25	TM 160.30	TM 215.30	TM 215.40
Drum diameter (mm)	100	113	127	138	160	160	215	215
Shaft diameter (mm)	25	25	25	25	25	30	30	40
Power (kW)	0.05-0.37	0.04-0.55	0.10-1.1	0.10-1.1	0.10-0.75	0.10-2.2	0.10-2.2	0.37-5.5
Speed (m/s)	0.007-3.60	0.008-4.40	0.008-2.60	0.009-2.80	0.13-3.30	0.06-4.00	0.08-5.30	0.12-4.70

Drum motor type	TM 215B50	TM 273.40	TM 315.40	TM 315.50	TM 400A50	TM 400.60	TM 500A60	TM 500A75
Drum diameter (mm)	215	273	315	315	400	400	500	500
Shaft diameter (mm)	50	40	40	50	50	60	60	75
Power (kW)	1.5-4.0	0.37-5.5	0.37-5.5	1.1-11	1.1-11	1.5-22	1.5-22	11-30
Speed (m/s)	0.18-0.31	0.17-5.00	0.18-5.20	0.16-4.40	0.20-4.80	0.20-4.60	0.25-4.70	0.80-3.20

Drum motor type	TM 620A75	TM 630A100	TM 800A100	TM 800A130
Drum diameter (mm)	620	630	800	800
Shaft diameter (mm)	75	100	100	130
Power (kW)	11-30	22-55	22-55	55-132
Speed (m/s)	1.00-3.90	1.00-4.00	1.25-5.10	1.60-4.50

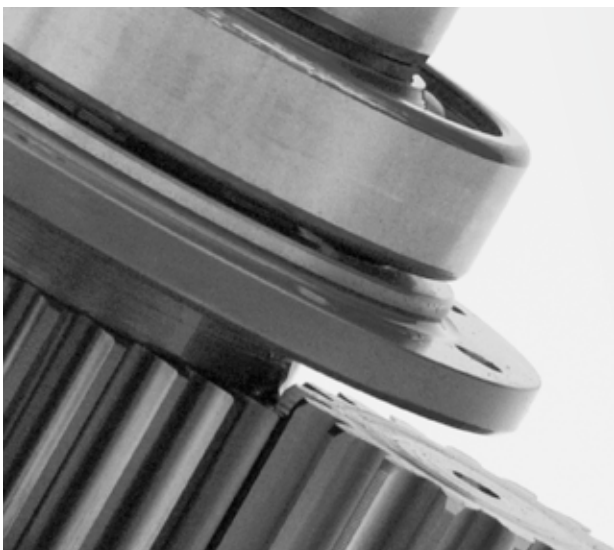

Design benefits

- Robust, industrial design
- Fully enclosed
- Oil filled
- Well-sized gears and bearings

Installation advantages

- Easy to install
- Compact and reliable
- Easy to clean
- Virtually maintenance free
- Low Life Cycle Costs





Van der Graaf

Power Transmission Equipment

Contact us

Netherlands

Van der Graaf B.V.
De Weijert 14
P.O. Box 3
8325 ZG Vollenhove
Tel: 00 31 527 241441
Fax: 00 31 527 241488
E-mail: info@vandergraafpte.nl
www.vandergraafpte.nl



Canada

Van der Graaf Inc.
2 Van der Graaf Court
Brampton
Ontario L6T 5R6
Tel: 00 1 905 793 8100
Fax: 00 1 905 793 812
E-mail: info@vandergraaf.com
www.vandergraaf.com



Great Britain

Van der Graaf U.K. Ltd.
Unit 23, The Metro Centre
Welbeck Way Woodston
Peterborough PE2 7UH
Tel: 00 44 1733 391777
Fax: 00 44 1733 391044
E-mail: sales@vandergraaf.co.uk
www.drummotor.com



USA

Van der Graaf Corp.
51515 Celeste
Shelby Township
48315 Michigan
Tel: 00 1 866 595 3292
Fax: 00 1 888 326 0089



Germany

Van der Graaf GmbH
Rheiner Straße 24 B
48432 Rheine-Mesum
Tel: 00 49 5975 306210
Fax: 00 49 5975 3062120
E-mail: info@vandergraaf.de
www.vandergraaf.de



Sweden

Van der Graaf Scandinavia AB
Spinngatan 2
267 73 Billesholm
Tel: 00 46 42 22 0802
Fax: 00 46 42 22 0803
E-mail: info@vandergraaf.se
www.vandergraaf.se



Finland

Van der Graaf Scandinavia AB
Tel: 00 358 400 419063
E-mail: info@vandergraaf.fi
www.vandergraaf.fi

BRUYNNOOGHE

transportbanden

Bruynooghe nv

Hillemolenstraat 1

B-8830 Hooglede

+32 (0) 51 70 35 35

info@bruynooghe-nv.be

www.bruynooghe-nv.be