

TM 215-40

Product information

Drummotors

TM 215-40



Van der Graaf
Power Transmission Equipment

www.vandergraafpte.nl

The TM 215's playground







TM 215-40

A wide range of applications

Van der Graaf has achieved a prominent position on both the domestic and international market with its "GV" Drummotors.

The "GV" Drummotor has found success in a wide range of applications including the following: automotive, X-ray, construction, postal, courier, mining, aggregate, airline baggage, package flow, tyre manufacturing, fish processing, poultry processing, meat processing, agriculture, fruit and vegetable, farming, forestry, baking, dairy and many more.

4	Introduction
5	Selection table
6	Selection table Dahlander motors
7	Dimensions Drummotors mild steel
8	Dimensions Drummotors stainless steel
9	Dimensions Taildrums mild steel
10	Dimensions Taildrums stainless steel
11	Dimensions bracket
12	Cable exit
13	Cross sectional / parts description
16	Options
19	Product range
20	Contact us



Selection table

TYPE TM 215.40	Power kW	Beltspeed m/s at 50 Hz						Min. L mm Design A	Min. L mm Design B	Full load curr. 400 V - 50 Hz I = ... A	Weight kg L=500				
		Beltpull N													
275 275 ZV	5,50	4,70 1100 2,00 2610	3,90 1340 1,70 3075	3,50 1495 1,50 3485	2,80 1865 1,40 3730	2,50 2090 1,30 4020	1,10 4750	500	550	11,0	79				
255 255 Z 255 ZV	4,00	4,70 810 2,00 1900 1,50 2535	3,90 975 1,70 2235 1,40 2715	3,50 1085 1,30 2925	2,80 1355 1,10 3455	2,50 1520 1,00 3800	0,90 4220	500	550	8,0	76				
440 440 ZV	3,00	2,90 985 1,00 2850	2,40 1190 0,85 3355	2,00 1425 0,75 3800	1,80 1585 0,70 4070	1,40 2035 0,65 4385	1,25 2280	500	550	6,6	76				
430 430 ZV	2,20	2,90 720 0,85 2460	2,40 870 0,70 2985	2,10 995 0,65 3215	1,70 1230 0,60 3485	1,40 1495 0,55 3800	1,25 1670 0,50 4180	1,00 2090 0,45 4645	0,90 2320	425	500	4,7	73		
420 420 ZV	1,50	2,90 490 0,60 2375	2,40 595 0,55 2590	2,10 680 0,50 2850	1,70 840 0,45 3165	1,40 1020 0,40 3565	1,25 1140	1,00 1425	0,90 1585	0,80 1780	0,70 2035	425	500	3,6	71
620 620 ZV	1,50	1,60 890 0,36 3960	0,85 1675 0,34 4190	0,31 4595	0,28 5090			500	550	3,7	76				
415 415 Z 415 ZV	1,10	2,90 360 0,60 1740 0,55 1900 0,40 2615	2,40 435 0,50 2090	2,10 500 0,45 2320	1,80 580	1,40 745	1,25 835	1,00 1045	0,90 1160	0,80 1305	0,70 1495	425	500	2,9	69
615 ZV	1,10	0,36 2950	0,34 3075	0,31 3370	0,28 3730	0,26 4020		425	500	2,9	73				
610 610 Z 610 ZV	0,75	1,40 510 0,36 1980 0,28 2545	1,20 595 0,34 2095 0,26 2740	0,90 790 0,31 2300	0,85 840	0,65 1095	0,60 1190	0,50 1425	0,45 1585	0,40 1780		425	500	2,5	71
810 ZV	0,75	0,23 3100	0,21 3395	0,19 3750				425	500	2,7	73				
675 675 Z	0,55	1,40 375 0,36 1450	1,20 435 0,34 1535	0,90 580 0,31 1685	0,85 615 0,28 1865	0,65 805 0,26 2010	0,60 870	0,50 1045	0,45 1160	0,40 1305		425	500	1,9	69
875 Z 875 ZV	0,55	0,23 2270 0,21 2490	0,19 2750					425	500	2,2	71				
1275 ZV	0,55	0,17 3075	0,15 3485	0,12 4355				500	550	2,6	76				
805 805 Z	0,37	1,10 320 0,28 1255	0,85 415 0,25 1405	0,70 500 0,23 1530	0,65 540 0,21 1675	0,50 705 0,19 1850	0,45 780	0,40 880	0,35 1005	0,30 1170		425	500	1,8	69
1205 1205 Z 1205 ZV	0,37	0,55 640 0,17 2070 0,12 2930	0,15 2345					425	500	2,0	73				

Available standard facewidth's: 425 - 450 - 500 - 550 - 600 - 650 - 700 - 750 - 800 - 850 - 900 - 950 - 1000 mm

When an electro-mechanical brake is fitted, the minimum facewidth is increased by 100 mm

The total weight of a Drummotor grows approx. 4,5 kg per 100 mm

Available torque: (Beltpull N x drum diameter m) / 2 Nm

Selection table Dahlander motors

TYPE TM 215.40	Power kW	Beltspeed m/s at 50 Hz								Min. L mm Design A	Min. L mm Design B	Full load curr. 400 V - 50 Hz I = ... A	Weight kg L=500
		Beltpull N											
430/240 430/240 ZV	2,20/3,00	2,40/4,80 870/595 0,85/1,70 2460/1675	2,10/4,20 995/680 0,70/1,40 2985/2035	1,70/3,40 1230/840 0,65/1,30 3215/2190	1,40/2,80 1495/1020 0,60/1,20 3485/2375	1,25/2,50 1670/1140 0,55/1,10 3800/2590	1,00/2,00 2090/1425 0,50/1,00 4180/2850	0,45/0,90 4645/3165		500	550	5,0/6,9	76
418/230 418/230 ZV	1,30/2,20	2,40/4,80 515/435 0,70/1,40 1765/1495 0,55/1,10 2245/1900	2,10/4,20 590/500 0,60/1,20 2060/1740 0,50/1,00 2470/2090	1,70/3,40 725/615 0,45/0,90 2745/2320	1,40/2,80 880/745 0,40/0,80 3090/2615	1,25/2,50 990/835	1,00/2,00 1235/1045	0,90/1,80 1370/1160	0,80/1,60 1545/1305	425	500	3,1/4,6	73
816/430 ZV	1,20/2,20	0,35/0,70 3255/2985	0,33/0,66 3455/3165	0,30/0,60 3800/3485	0,27/0,54 4220/3870	0,25/0,50 4560/4180	0,23/0,46 4955/4545			500	550	3,8/4,3	76
810/420 810/420 ZV	0,75/1,50	1,40/2,80 510 0,40/0,80 1780	1,20/2,40 595 0,35/0,70 2035	1,10/2,20 650	0,85/1,70 840	0,70/1,40 1020	0,60/1,20 1190	0,50/1,00 1425	0,45/0,90 1585	500	550	3,3/4,6	76
875/415 875/415 Z 875/415 ZV	0,55/1,10	1,10/2,20 475 0,30/0,60 1740 0,27/0,54 1935	0,85/1,70 615 0,25/0,50 2090	0,70/1,40 745 0,23/0,46 2270	0,60/1,20 870	0,50/1,00 1045	0,45/0,90 1160	0,40/0,80 1305	0,35/0,70 1495	425	500	2,4/2,5	73
805/410 805/410 Z	0,37/0,75	1,10/2,20 325 0,30/0,60 1190 0,27/0,54 1320	0,85/1,70 420	0,70/1,40 510	0,60/1,20 595	0,50/1,00 715	0,45/0,90 790	0,40/0,80 890	0,35/0,70 1020	425	500	1,8/1,5	71

Available standard facewidth's: 425 - 450 - 500 - 550 - 600 - 650 - 700 - 750 - 800 - 850 - 900 - 950 - 1000 mm

When an electro-mechanical brake is fitted, the minimum facewidth is increased by 100 mm

The total weight of a Drummotor grows approx. 4,5 kg per 100 mm

Available torque: (Beltpull N x drum diameter m) / 2 Nm

Dimensions Drummotors stainless steel

TM 215A40 CR

TM 215A40 CR, stainless steel Drummotor with polyamide junctionbox and CR sealing

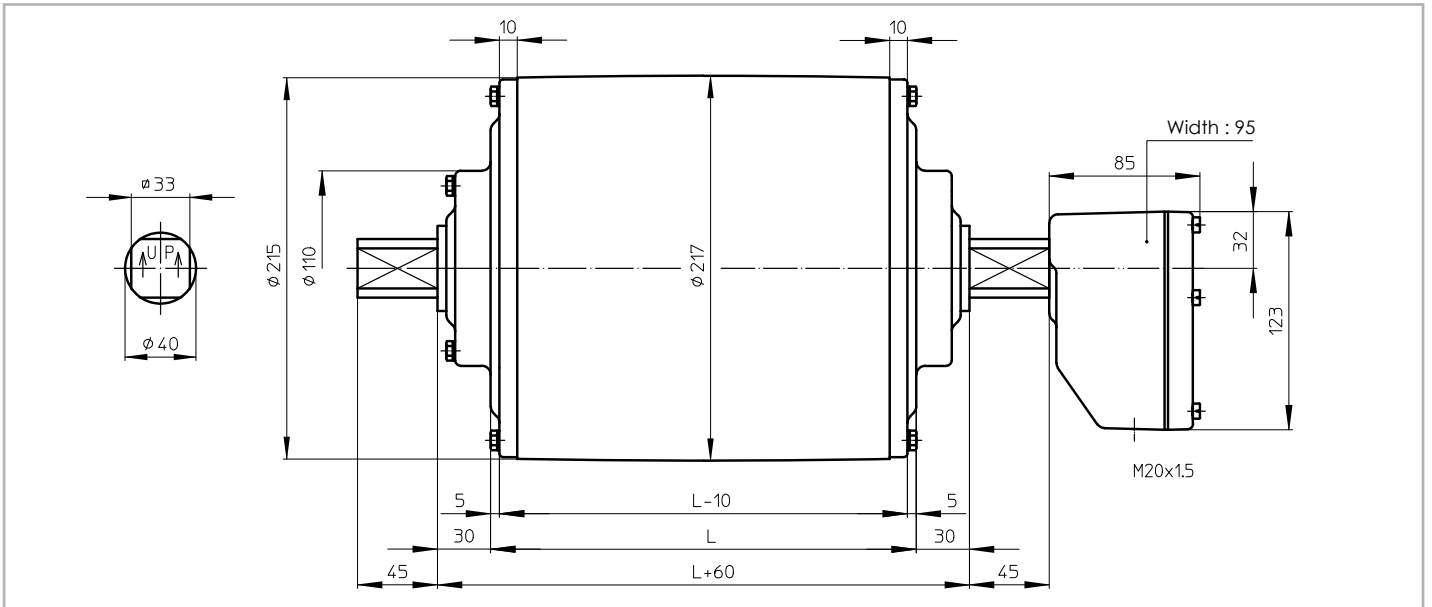

TM 215B40 CR

TM 215B40 CR, stainless steel Drummotor with polyamide junctionbox and CR sealing

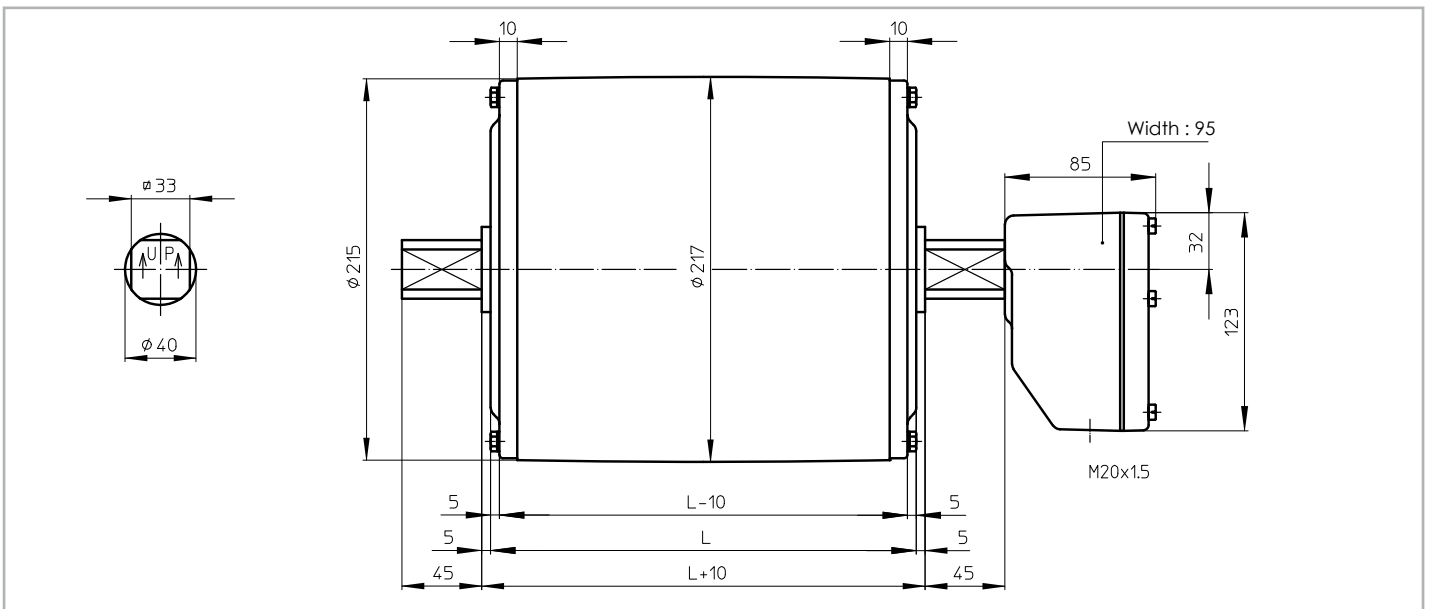



Dimensions Taildrums mild steel

KT 215A40

KT 215A40, mild steel Taildrum

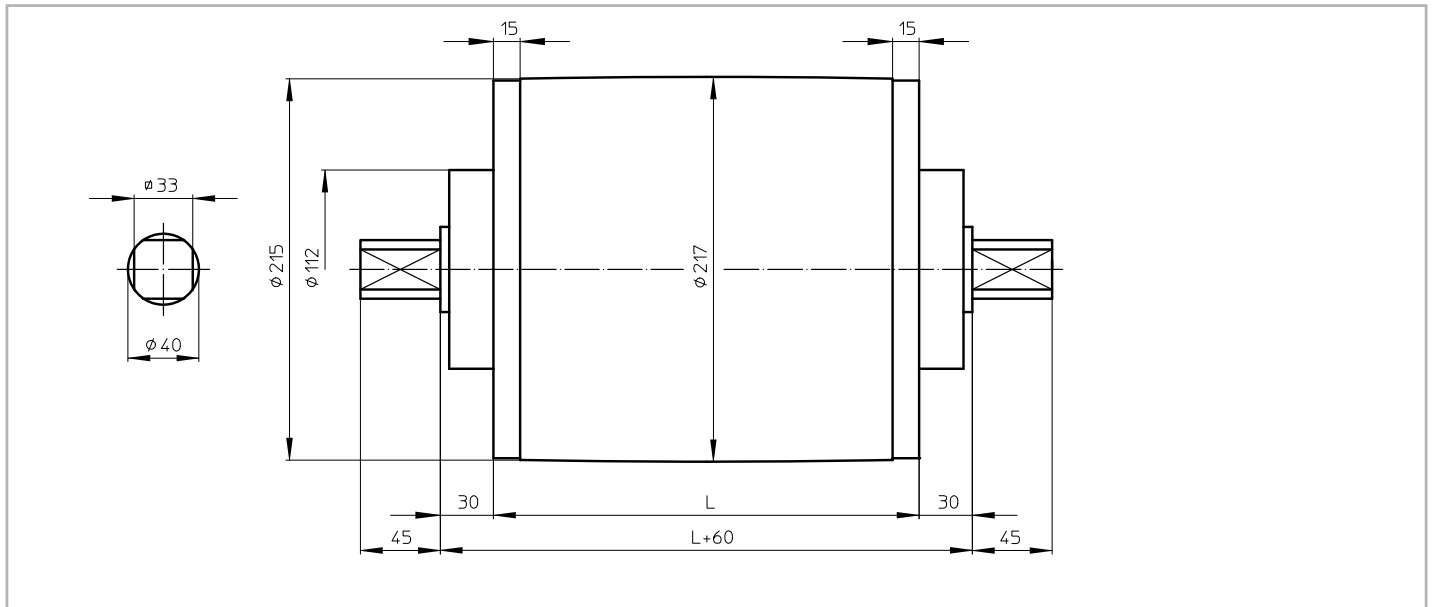

KT 215B40

KT 215B40, mild steel Taildrum

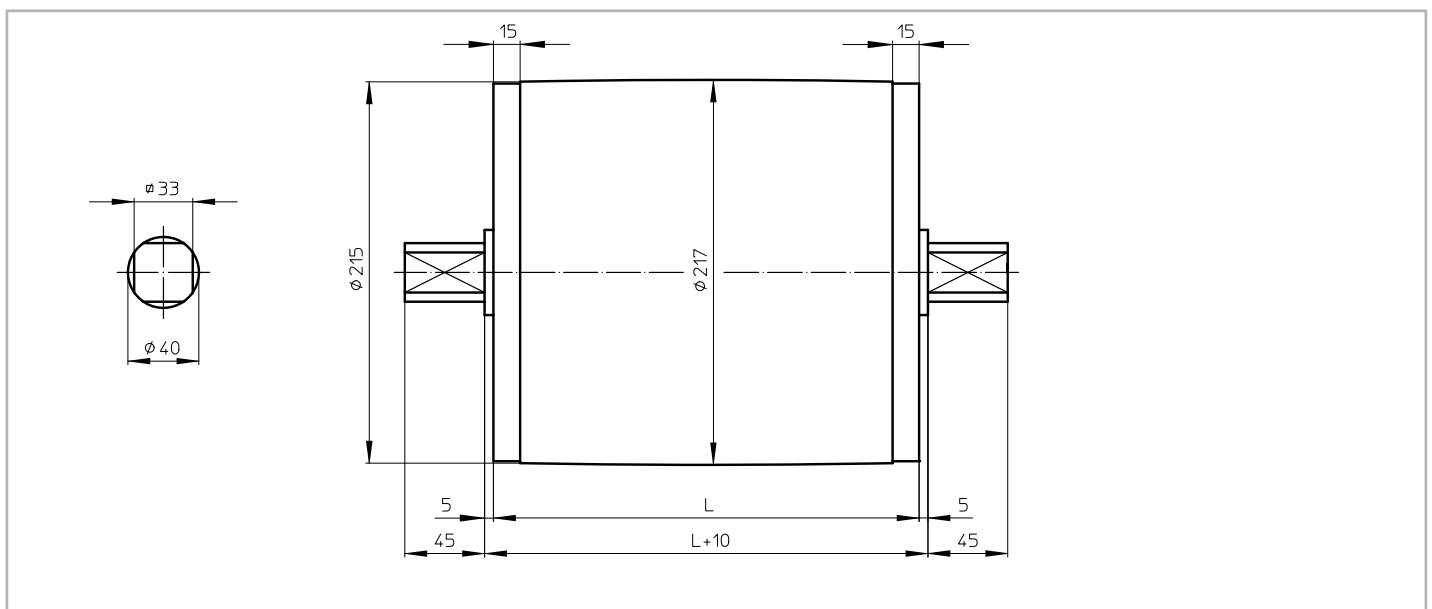

Dimensions Taildrums stainless steel

KT 215A40 CR

KT 215A40 CR, stainless steel Taildrum with CR sealing

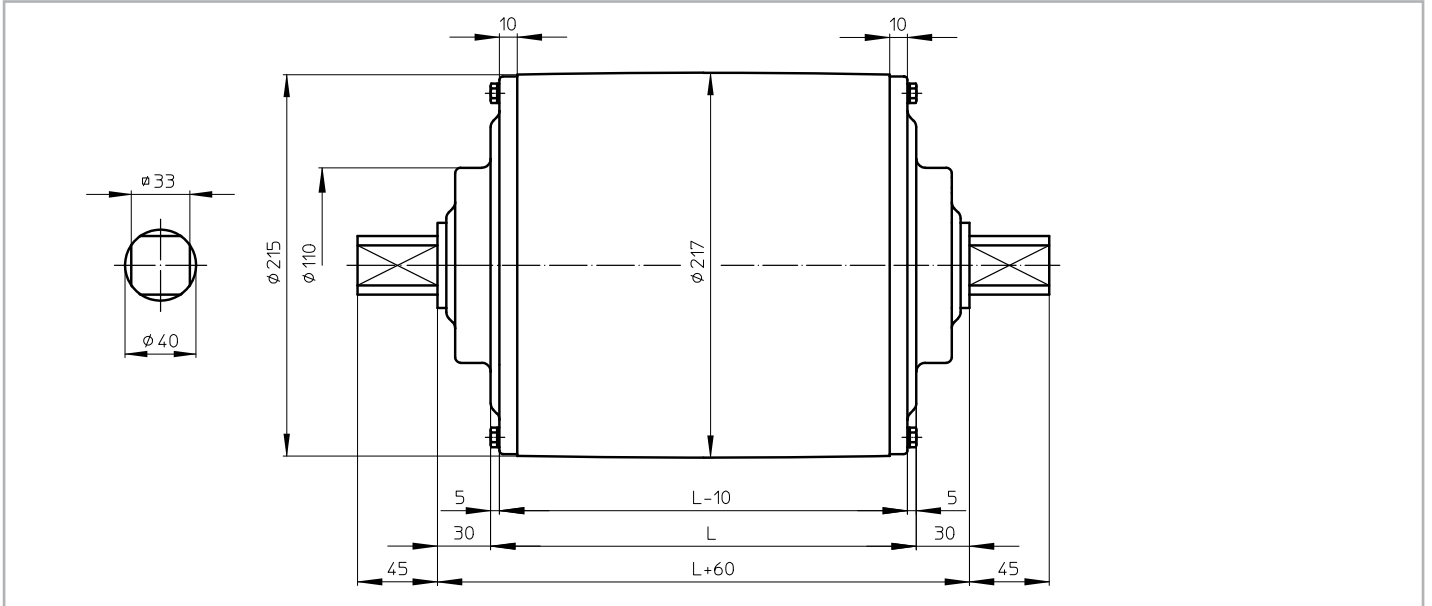

KT 215B40 CR

KT 215B40 CR, stainless steel Taildrum with CR sealing

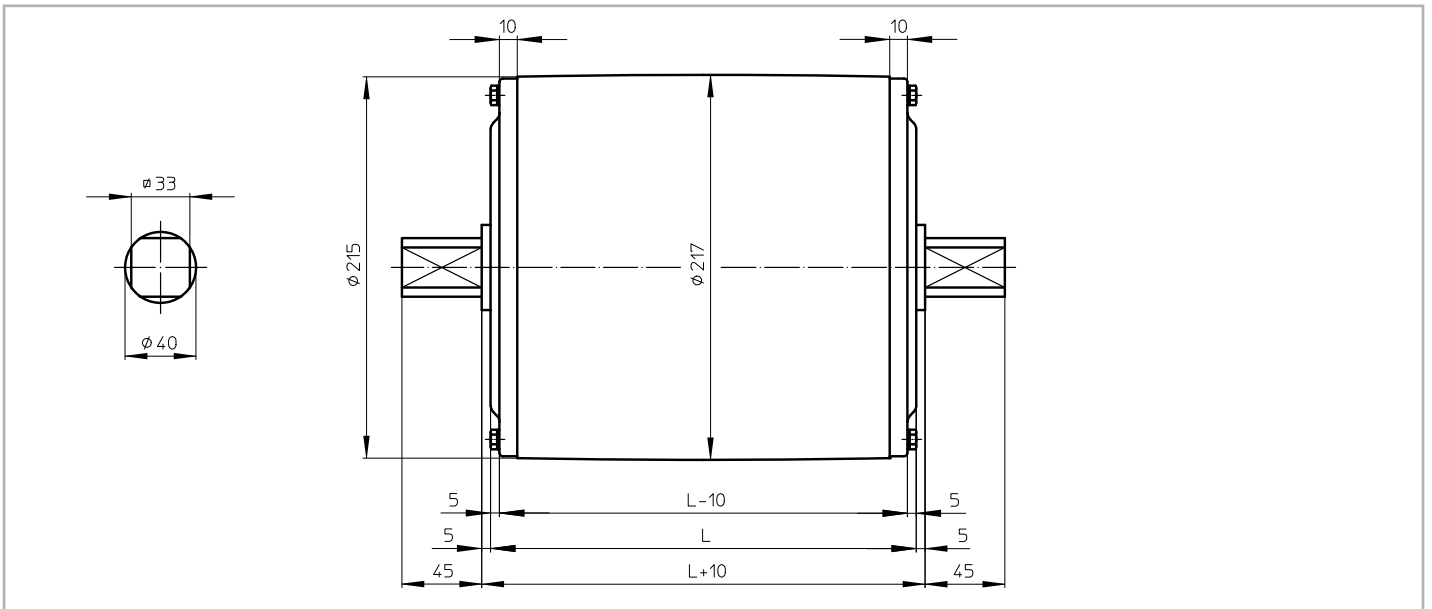



Dimensions bracket

AB 40

AB 40, cast iron or stainless steel bracket

Weight: 4,2 kg per pair

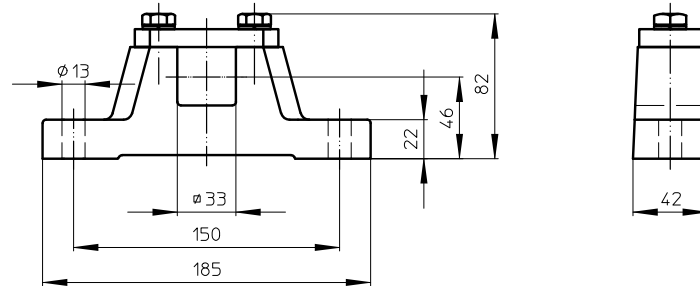

Cable exit

Standard design of a TM 215-40 is with a cast iron junctionbox. For stainless steel design, this can be either a polyamide or stainless steel junctionbox.

On request a Drummotor can be fitted with a cable. In this case it is important to know the available voltage (preferably 1 voltage), the length of the cable, whether the cable is shielded or not and the type of cable exit.

An overview of available cable exits is shown below.

Option 1

Straight cable exit with cable gland

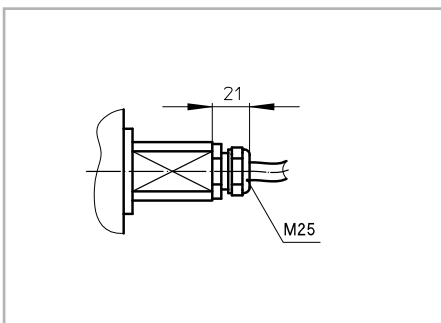

Option 3

Elbow cable exit with cable gland
(minimum facewidth increases with 50 mm)

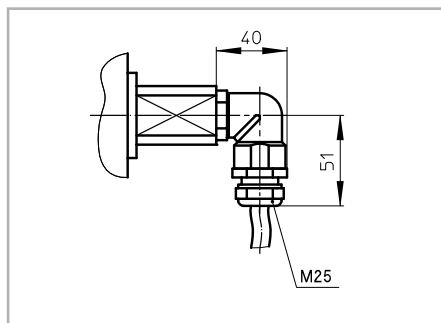

Option 4

Open cable exit (minimum facewidth increases with 50 mm)

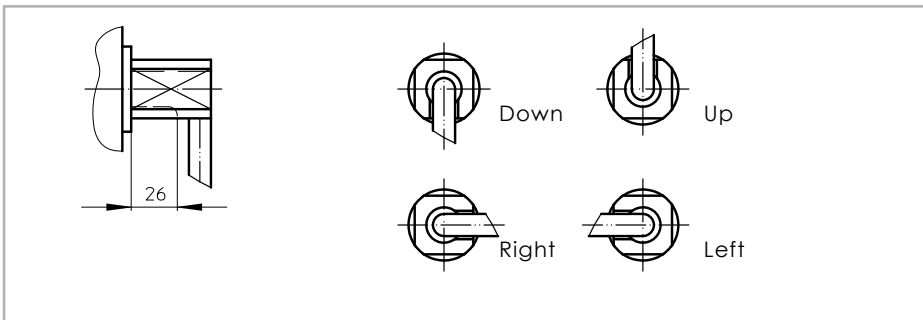



TM 215A40

Legenda

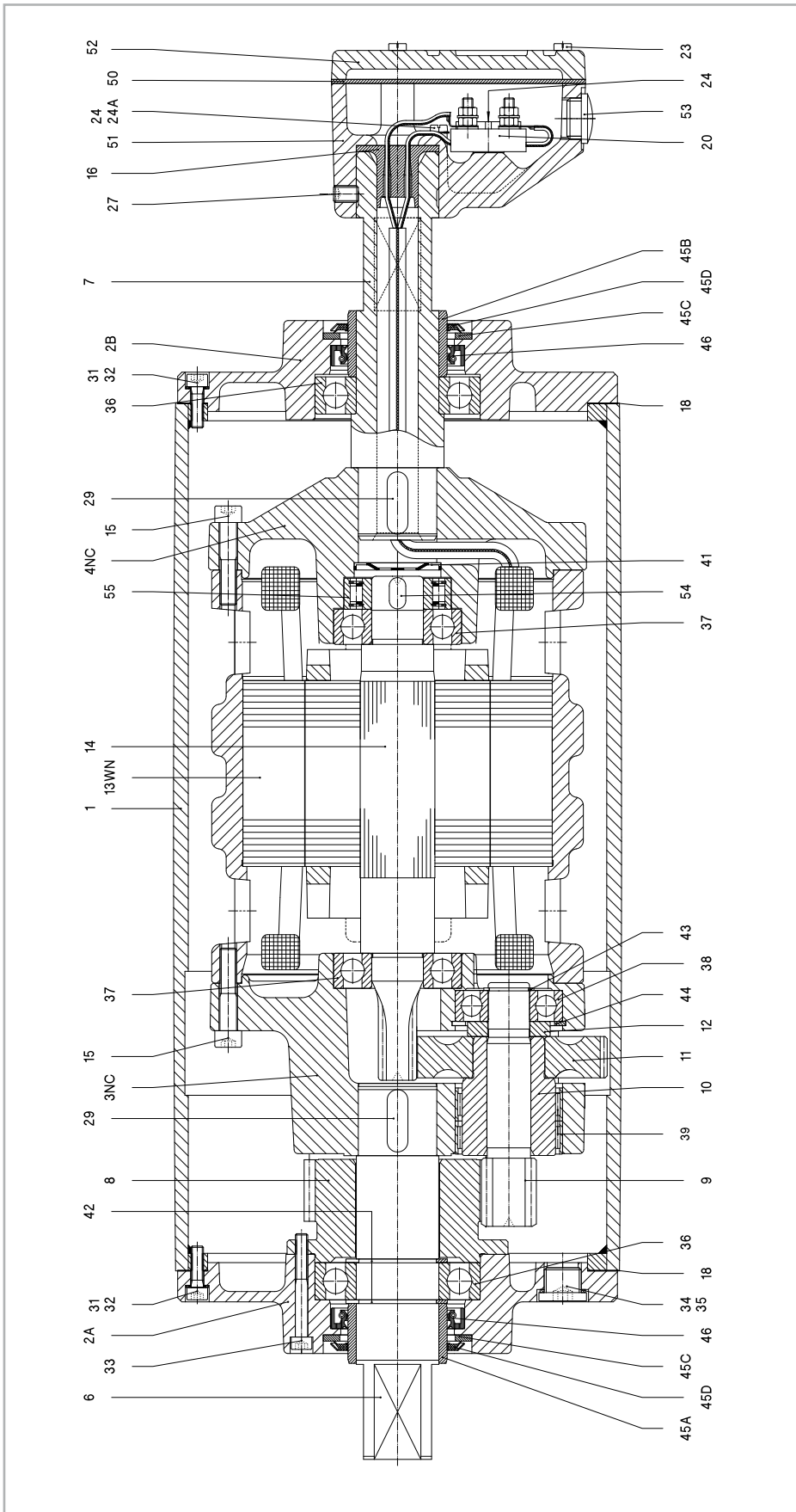

Remark: Drummotor also available in B-design (TM215B40)

1	Shell	39	Needlebearing	50	Seal
2A	Endflange	41	Disc	51	Junctionbox
2B	Endflange	42	Circlip	52	Junctionbox cover
3NC	Gearhousing	43	Circlip	53	Stopping plug
4NC	Motoflange	44	Circlip	54	Key
6	Shaftend	45A	Bearing race	55	Backstop
7	Hollow shaft	45B	Bearing race	57	Dataplate
8	External gear	45C	Shim plated		
9/10	Pinion with bush	45D	Gammaring		
11	Gear	46	Olised		
12	Distance ring	27	Set screw		
13WN	Stator	29	Key		
14	Rotor	31	Int. hex screw		
15	Int. hex screw	32	Washer		
16	Cable passage	33	Int. hex screw		
18	Gasket	34	Fillerplug		
20	Terminalboard	35	Washer		
23	Cyl. head screw	36	Ballbearing		
24	Cyl. head screw	37	Ballbearing		
24A	Toothed lock washer	38	Ballbearing		
27		37			
29		41			
31		42			
32		43			
33		44			
34		45A			
35		45B			
36		45C			
37		45D			
38		46			
39		18			
41		20			
42		24			
43		24A			
44		27			
45A		29			
45B		31			
45C		32			
45D		33			
46		34			
47		35			
48		36			
49		37			
50		38			
51		43			
52		44			
53		45A			
54		45B			
55		45C			
57		45D			

Cross sectional / parts description

TM 215A40 Z

Legenda

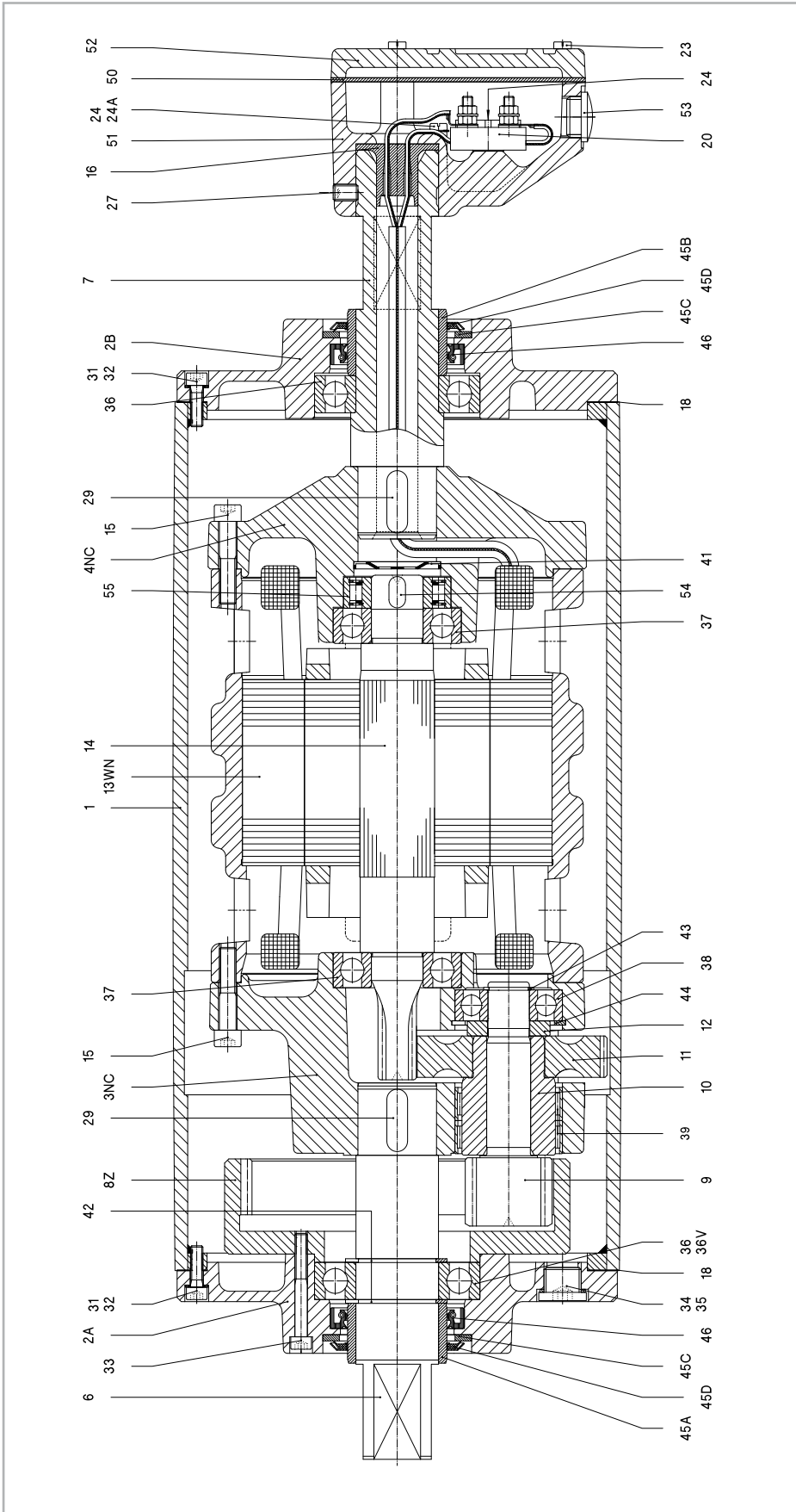

Remark: Drummotor also available in B-design (TM215B40 Z)

1	Shell	38	Ballbearing	46	Oilseal
2A	Endflange	39	Needlebearing	50	Seal
2B	Endflange	41	Disc	51	Junctionbox
3NC	Gearhousing	42	Circlip	52	Junctionbox cover
4NC	Motoflange	43	Circlip	53	Stopping plug
6	Shaftend	44	Circlip	54	Key
7	Hollow shaft	45A	Bearing race	55	Backstop
8Z	Internal gear	45B	Bearing race	57	Dataplate
9/10	Pinion with bush	45C	Shim plated		
11	Gear	45D	Gammaring		
12	Distance ring	27	Set screw		
13WN	Stator	29	Key		
14	Rotor	31	Int. hex screw		
15	Int. hex screw	32	Washer		
16	Cable passage	33	Int. hex screw		
18	Gasket	34	Fillerplug		
20	Terminalboard	35	Washer		
23	Cyl. head screw	36	Ballbearing		
24	Cyl. head screw	36V	Cyl. roller bearing		
24A	Toothed lock washer	37	Ballbearing		
27	Set screw				
29	Key				
31	Int. hex screw				
32	Washer				
33	Int. hex screw				
34	Fillerplug				
35	Washer				
36	Ballbearing				
36V	Cyl. roller bearing				
37	Ballbearing				
38	Ballbearing				
39	Needlebearing				
41	Disc				
42	Circlip				
43	Circlip				
44	Circlip				
45A	Bearing race				
45B	Bearing race				
45C	Shim plated				
45D	Gammaring				
46	Oilseal				
50	Seal				
51	Junctionbox				
52	Junctionbox cover				
53	Stopping plug				
54	Key				
55	Backstop				
57	Dataplate				



KT 215A40

Legenda

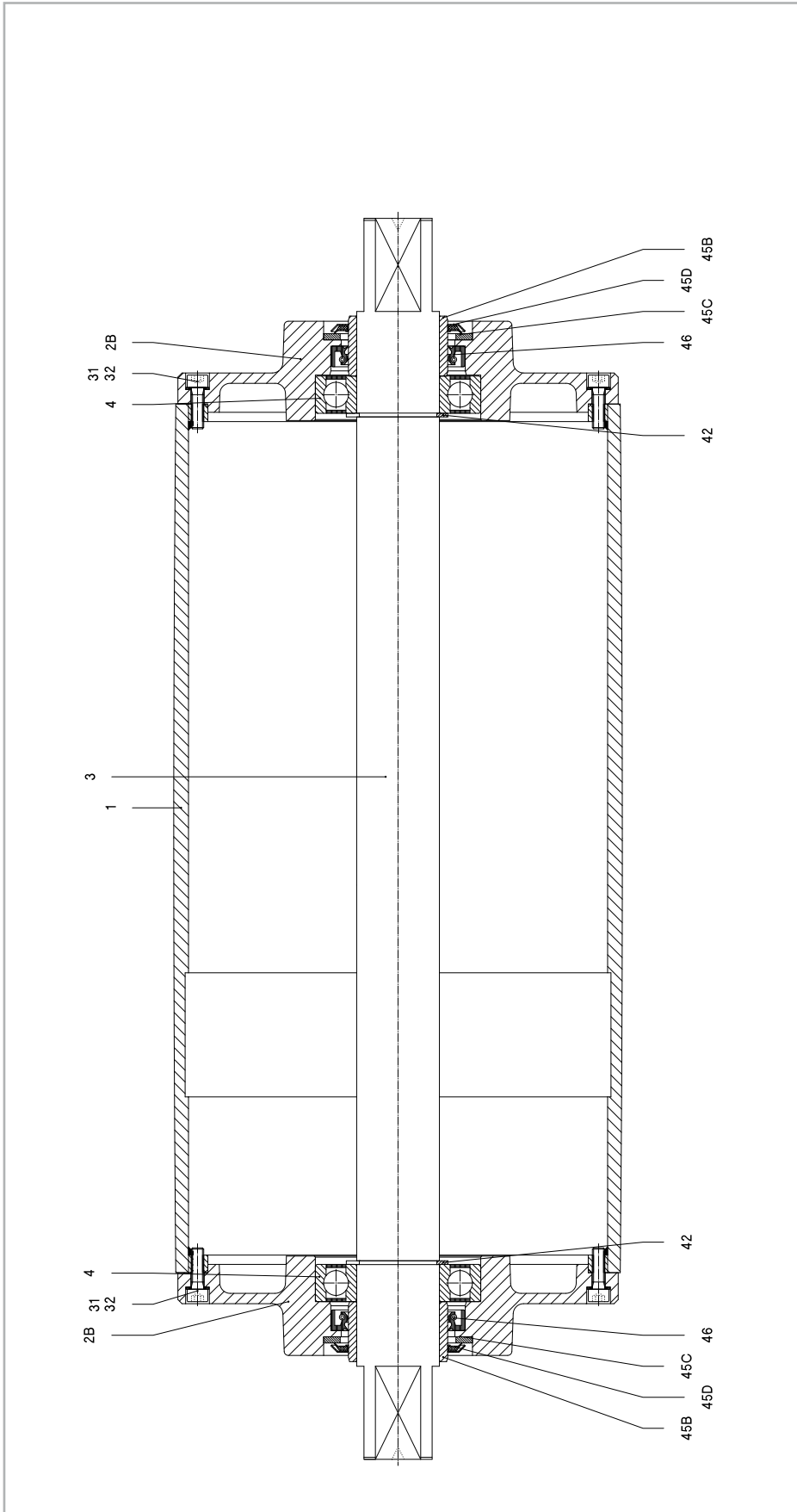

Remark: Taildrum also available in B-design (KT215B40)

1	Shell	42	Circlip
2B	Endflange	45B	Bearing race
3	Shaft	45C	Shim plated
4	Ballbearing	45D	Gammaring
31	Int. hex screw	46	Oilseal
32	Washer		

Material

The external parts of the Drummotor are made from mild steel and cast iron. Depending on the application it is also possible to manufacture in stainless steel (complete or part). You can choose between stainless steel 304 (general food industry) and stainless steel 316 (salt water applications).

Backstop - Brake

If an inclined belt conveyor is stopped fully loaded, it could run backwards.

To prevent this we can install a backstop. One of the bearings in the Drummotor is replaced by a one way bearing. The way this bearing is installed determines the direction of rotation of the drum. TBRH indicates a cw rotation and TBLH ccw.

In situations where a Drummotor needs to be able to drive in both directions it is not possible to use a backstop. In this case we use a brake. When an declined belt or a horizontal belt needs to be stopped quickly to pick or place items a brake is the best solution.

Inclined position

Sometimes a Drummotor needs to be installed on an inclined or even vertical position. This is possible, but we need to make adjustments to the oil level in the drum as the oil will flow to the lower side of the Drummotor causing the top bearing to run without lubrication. To prevent problems we will need to know the installation angle so we can fill the drum with extra oil and fit a double sealed bearing on the upper side.

Thermal protection

A Van der Graaf Drummotor can be fitted with thermal protection. This consists of either a thermistor (PTC) or bi-metal (klixon). We install these on each phase of the electric motor.

Encoder - Sensor bearing

In certain applications it is required to measure the speed or position of a conveyor belt. For this type of application we can install an encoder or sensor bearing to accurately measure rotational speed of the Drummotor.

The accuracy needed will determine the type of encoder or sensor used.

Lagging

The power produced by the Drummotor has to be transferred to the belt and lagging is used to give more friction between the Drummotor and the conveyor belt. Van der Graaf can fit your Drummotor with different kinds of lagging.

There is a difference between cold and hot vulcanised lagging. Cold vulcanised means the lagging is glued to the Drummotor usually in sheet form and the join 'welded' together. Hot vulcanising is a process where the shell is wrapped around with thin layers of rubber. The shell with the rubber is then baked in an autoclave fusing the layers together creating a seamless finish.

It is possible to cut grooves (e.g chevron or diamond) in the lagging.

Sprockets

Do you wish to use a Drummotor to drive modular belts? Van der Graaf can help you! Fitting sprockets suitable for various types of modular belts is a simple solution. The Drummotor is manufactured with a cylindrical shell and machined with a patented 'keying' system. The sprockets are simply 'slid' on and locked securely into position.

Sealings for mild steel Drummotors

RB sealing - IP 66



This is Van der Graaf's standard sealing. This type of sealing will work in most conditions.

RBS sealing - IP 66



This sealing is specifically designed for those applications where high water pressure is used for cleaning.

HD sealing - IP 66



This sealing is designed for abrasive applications, like sand, gravel and soil.

Sealings for stainless steel Drummotors

CR sealing - IP 66



This is our standard sealing for stainless steel Drummotors, a very effective, multi labyrinth sealing.

UW sealing - IP 68



This sealing is suitable for under water applications. The maximum depth is approx 2,5 m.

Options

Specification	Standard	Optional
Construction		
Shafts and bolts	Mild steel	Stainless steel
Endflanges	Cast iron	Stainless steel
Shell	Mild steel	Stainless steel
Junctionbox	Cast iron	Stainless steel or polyimide
Cable		Shielded or non-shielded
Sealing mild steel	RB	RBS, HD
Sealing stainless steel	CR	UW
Shell		
Crowned	•	
Cylindrical		•
Balanced		•
Lagging, cold vulcanised		•
Lagging, hot vulcanised		•
Lagging, FDA approved		•
Fitted with grooves, patterns		•
Sprockets		•
Electro motor		
Three-phase asynchronous	•	
Power supply ($P \leq 3$ kW)	230/400 V - 50 Hz	Other voltages and frequencies on request
Power supply ($P > 3$ kW)	400/690 V - 50 Hz	Other voltages and frequencies on request
Two speed (Dahlander)		•
Twin drive (double power)		•
Insulation class	F	H
Thermal protection		Bi-metal or thermistor
Run by frequency inverter	•	
Other options		
Food grade oil		•
Backstop, mechanical		•
Brake, electro mechanical		•
Clutch brake, electro mechanical		•
Inclined or vertical position		•
Other facewidth's		•
Different shaft designs		•
Encoder or sensor bearing in Drummotor		•
Encoder or sensor bearing in Taildrum		•
Certificates		
CE	•	
UL		•
CSA		•
ATEX zone 22, dust		•
UW Under water application (IP68)		•



Product range

Our products, an overview

Drum motor type	TM 100B25	TM 113B25	TM 127.25	TM 138.25	TM 160.25	TM 160.30	TM 215.30	TM 215.40
Drum diameter (mm)	100	113	127	138	160	160	215	215
Shaft diameter (mm)	25	25	25	25	25	30	30	40
Power (kW)	0.05-0.37	0.04-0.55	0.10-1.1	0.10-1.1	0.10-0.75	0.10-2.2	0.10-2.2	0.37-5.5
Speed (m/s)	0.007-3.60	0.008-4.40	0.008-2.60	0.009-2.80	0.13-3.30	0.06-4.00	0.08-5.30	0.12-4.70

Drum motor type	TM 215B50	TM 273.40	TM 315.40	TM 315.50	TM 400A50	TM 400.60	TM 500A60	TM 500A75
Drum diameter (mm)	215	273	315	315	400	400	500	500
Shaft diameter (mm)	50	40	40	50	50	60	60	75
Power (kW)	1.5-4.0	0.37-5.5	0.37-5.5	1.1-11	1.1-11	1.5-22	1.5-22	11-30
Speed (m/s)	0.18-0.31	0.17-5.00	0.18-5.20	0.16-4.40	0.20-4.80	0.20-4.60	0.25-4.70	0.80-3.20

Drum motor type	TM 620A75	TM 630A100	TM 800A100	TM 800A130				
Drum diameter (mm)	620	630	800	800				
Shaft diameter (mm)	75	100	100	130				
Power (kW)	11-30	22-55	22-55	55-132				
Speed (m/s)	1.00-3.90	1.00-4.00	1.25-5.10	1.60-4.50				

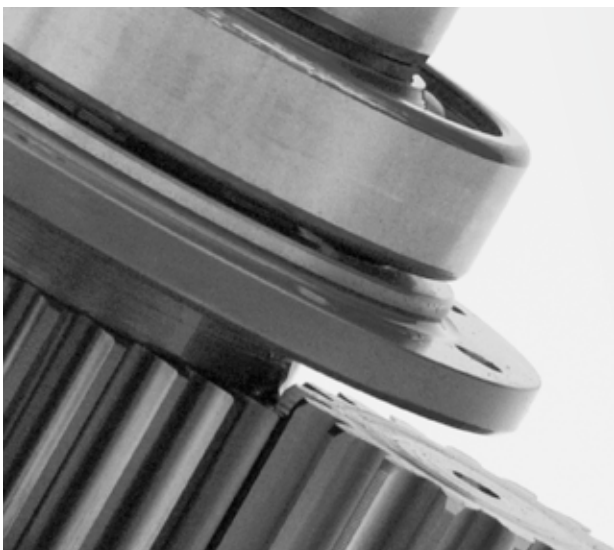

Design benefits

- Robust, industrial design
- Fully enclosed
- Oil filled
- Well-sized gears and bearings

Installation advantages

- Easy to install
- Compact and reliable
- Easy to clean
- Virtually maintenance free
- Low Life Cycle Costs





Van der Graaf

Power Transmission Equipment

Contact us

Netherlands

Van der Graaf B.V.
De Weijert 14
P.O. Box 3
8325 ZG Vollenhove
Tel: 00 31 527 241441
Fax: 00 31 527 241488
E-mail: info@vandergraafpte.nl
www.vandergraafpte.nl



Canada

Van der Graaf Inc.
2 Van der Graaf Court
Brampton
Ontario L6T 5R6
Tel: 00 1 905 793 8100
Fax: 00 1 905 793 812
E-mail: info@vandergraaf.com
www.vandergraaf.com



Great Britain

Van der Graaf U.K. Ltd.
Unit 23, The Metro Centre
Welbeck Way Woodston
Peterborough PE2 7UH
Tel: 00 44 1733 391777
Fax: 00 44 1733 391044
E-mail: sales@vandergraaf.co.uk
www.drummy.com



USA

Van der Graaf Corp.
51515 Celeste
Shelby Township
48315 Michigan
Tel: 00 1 866 595 3292
Fax: 00 1 888 326 0089



Germany

Van der Graaf GmbH
Rheiner Straße 24 B
48432 Rheine-Mesum
Tel: 00 49 5975 306210
Fax: 00 49 5975 3062120
E-mail: info@vandergraaf.de
www.vandergraaf.de



Sweden

Van der Graaf Scandinavia AB
Spingatan 2
267 73 Billesholm
Tel: 00 46 42 22 0802
Fax: 00 46 42 22 0803
E-mail: info@vandergraaf.se
www.vandergraaf.se



Finland

Van der Graaf Scandinavia AB
Tel: 00 358 400 419063
E-mail: info@vandergraaf.fi
www.vandergraaf.fi

BRUYNNOOGHE

transportbanden



Bruynooghe nv

Hillemolenstraat 1

B-8830 Hooglede

+32 (0) 51 70 35 35

info@bruynooghe-nv.be

www.bruynooghe-nv.be